



GLD-30 Gas Leak Detector

Installation, Operation & Maintenance

General: The Archer Instruments GLD-30 is an ambient air monitor, used to detect the presence of a target gas (or gases) and to alert operators or plant personnel in the event of a gas leak. The GLD-30 is available with sensors for Chlorine, Sulfur Dioxide and other gases.

Installing the GLD-30:

1. Controller:

- The GLD-30 controller is designed for wall-mounting. To protect the electronic circuitry and provide safe access to the controls during possible gas leaks, the controller should be installed outside of the space(s) where chemicals are stored.
- A separate compartment is provided for access to internal wire terminals. The two (2) terminal blocks can be removed in order to ease wiring connections.
- Wiring Connections - The bottom compartment on the GLD-30 enclosure houses the wiring terminal strips. Refer to the below wiring terminal diagrams:

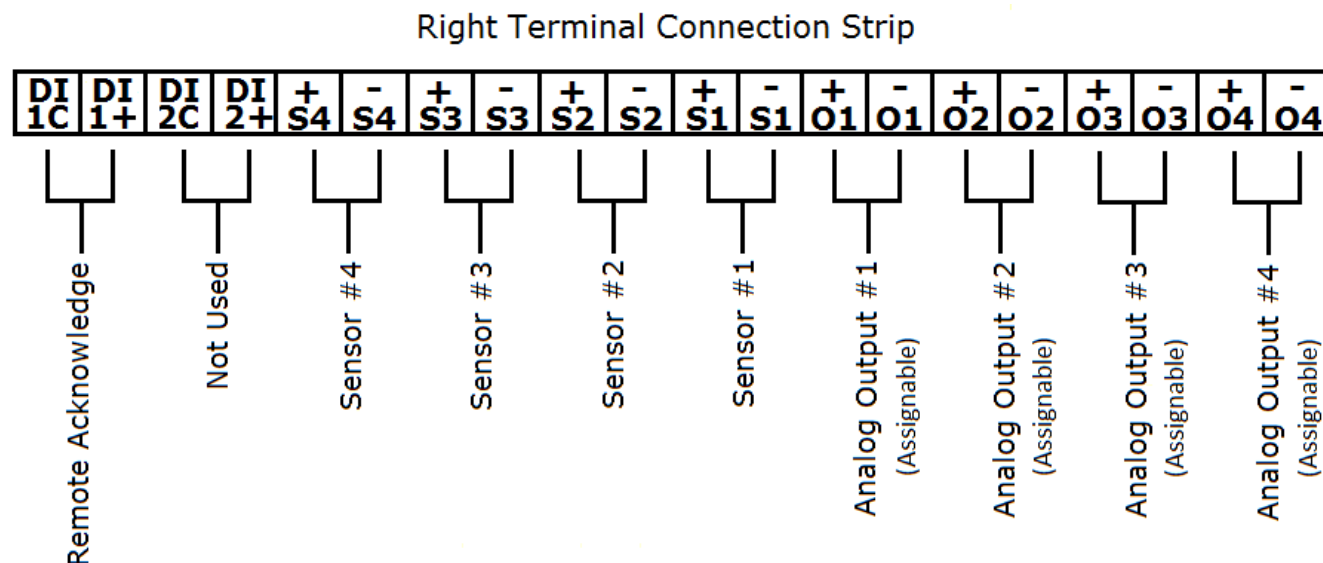
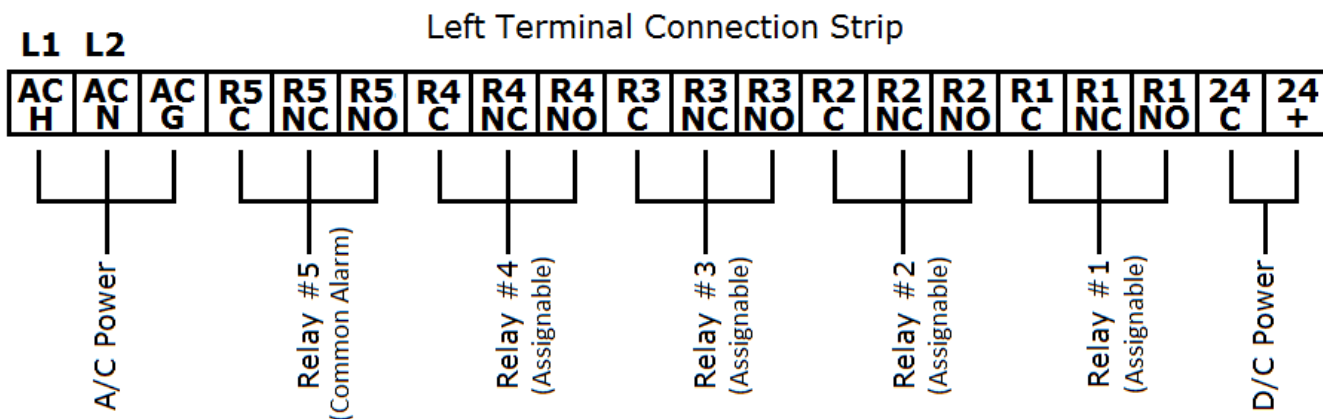

- Taking care to **ensure all enclosure penetrations are properly sealed** will help ensure a long operating life of the electronic circuitry in the controller.

- i. When using multiple sensors and / or multiple relays or analog outputs, it may be necessary to install the controller in a manner to allow space between the enclosure and the wall (using stand-offs) so the additional knockouts on the back of the terminal compartment can be used.
- e. Sensors are shipped pre-wired to the controller. Additional connections offered allow for the use of up to five (5) relays, up to four (4) analog outputs, MODBUS and a digital input for remote alarm acknowledgement (closure).

2. Sensor(s):

- a. Sensors are provided in enclosures designed for wall-mounting.
- b. When selecting a location for sensor installation, be aware that certain target gases are heavier than air (Chlorine & Sulfur Dioxide) and other gases are lighter than air (Ammonia). Sensors designed to detect heavier gases should be mounted 12" – 18" above the floor, while sensors designed to detect lighter gases should be mounted closer to the ceiling.
- c. Sensors should not be installed in a location where water or excessive moisture might come in contact with the sensor element, as this will damage the electrochemical sensing element.
- d. Sensors are shipped with a "calibration cap" installed over the sensor element. This cap is intended for use with calibration gas and must be removed for normal operation of the sensor. The cap is o-ring sealed and can be removed simply by twisting & pulling it out.

NOTES:

- 1) Sensors communicate with the controller via 4-20mA analog signal on a 24 VDC loop. Shielded cables must be used to avoid possible interference.
- 2) Sensors can be mounted up to 1,000 feet away from the controller.

Operating the GLD-30:

User Interface:

- 1) The user-interface consists of a four line, eighty character display and five pushbuttons.
 - a. Up Arrow – Allows for navigation "up" on certain screens and also allows for increasing displayed editable values on certain screens.
 - b. Down Arrow – Allows for navigation "down" on certain screens and also allows for decreasing displayed editable values on certain screens.

- c. Right Arrow – Allows for navigation “to the right” on certain screens.
- d. Left Arrow – This button allows the user to “back up” to the previous screen or menu.
- e. Enter – The enter button is used to move forward to the next screen and also to select options on screens where multiple options are presented.

Main Operating Screen:

- 1) During normal operation, the main screen will display the status of each sensor in use (up to four), with one sensor’s status detailed on each displayed line.
- 2) The displayed status includes the channel number, the actual reading displayed in engineering units, the gas type and the status (either “OK” or the alarm condition).
- 3) While on the main operating screen, pressing any button silences the horn (during alarm condition), pressing the up and down arrows simultaneously will reset the relays (following an alarm condition) and pressing ENTER accesses the password-protected configuration and diagnostic menus.

Password Protected Menus:

- 1) The GLD-30 password (needed to edit the channel configuration, perform calibrations, change relays & output functions or view the diagnostics menus) is 30.
- 2) The Menus: Once the password is entered, a menu appears with 12 possible selections. Use the up and down arrows to scroll through these selections:
 - a. CHX SETUP / ALARMS: Four selections allow the user to set-up each channel individually.
 - i. The initial screen under this section allows the user to enable or disable the channel. Change the selection using the up and down arrows. If the channel is disabled, pressing enter will return to the previous menu. If the channel is enabled:
 - ii. Alarm A Trip Level: Each channel incorporates two configurable alarm points. The first “Alarm A” is always enabled and the desired alarm level is entered on this screen using the up and down arrows.
 - iii. Alarm A Direction: Select either rising or falling. For typical gases (Chlorine, Sulfur Dioxide, Ammonia, Hydrogen Sulfide, etc.) this is always set to “rising”. This means normal condition is for the measured value to be below the alarm trip level. However, for sensors such as oxygen this is

changed to "falling".

- iv. Alarm A Delay: During an actual alarm condition, the controller will wait a certain number of seconds before activating the horn and alarm relay. This can be useful to reduce the possibility of false alarms. An actual alarm condition must exist continuously for the amount of time (seconds) entered. This is pre-set to 10 seconds and in most applications this need not be changed.
- v. Alarm A Latching / Non-Latching: Select desired relay behavior. If set to latching, the alarm relay(s) in use will not reset without an operator physically resetting the unit by pressing the up and down arrows. If this is set to "non-latching" the alarm relay(s) in use will reset on its own if the actual alarm condition clears.
- vi. Alarm B Enabled / Disabled: Each channel allows the user to set-up a second alarm trip point if desired. If so, enable Alarm B and repeat the configuration detailed above.
- vii. Engineering Units: Select the target gas to match the sensor in use. This is pre-set by the factory.
- viii. Sensor Range: Enter the full scale of the sensor in use. This is pre-set by the factory.
- ix. Locate Decimal Position: Place the decimal where appropriate. This is pre-set by the factory.
- x. Zero Calibration: The GLD-30 is equipped with simple zero and span calibration options. On this screen, the default selection displayed is to "Skip" the zero calibration. To do so, press enter. However, zero calibrations can easily be performed with or without the use of calibration gas. If the GLD30 is displaying a value close to zero (but not zero) and it is known that no target gas is in the atmosphere, select "Re-zero Channel 1" by pressing the up arrow and then ENTER.
- xi. Cal Change: This is the span calibration feature. Again, the default option displayed is to "Exit" (or skip) this calibration. Actual span calibrations can only be performed with the target calibration gas and the calibration cap mentioned earlier (under Installation 2.d.). Electronic calibration can also be performed using a 4-20mA signal-generating field meter. Unless the user is prepared to perform a span calibration in one of these ways, press ENTER to exit. If a span calibration is intended, press the up arrow to select the span calibration option and then press ENTER.

NOTE: It is the general recommendation of Archer Instruments that span calibrations only be performed by knowledgeable personnel and only in applications where very specific measurements are required. In general, the GLD-30 is employed as an *alarm* to notify personnel in the event of a gaseous leak. And in such applications it is generally not necessary to be

concerned about minor inaccuracies in the measured value.

- b. Relay X Function: Four selections allow the user to set up relays 1 through 4 for the desired alarm condition and desired function:
 - i. Assignment: This menu allows the user to select which alarm condition the indicated relay will be assigned for. All configured alarms for any channel in use, power failure and sensor failures are selectable.
 - ii. Relay Bias: Each relay is provided for use as normally open or normally closed. Select "Normally Open" or "Normally Closed" as desired.
- c. Controller Setup: This section allows the user to select whether or not a battery backup is in use and also allows the user to select the relay bias (normally open or normally closed) for the common relay (relay #5). Relay #5 will trip on any alarm condition. The general intent is for this relay to be used as a normally closed contact, to open upon power failure or electronic failure of the GLD-30 controller. However, the bias can be selected as normally open if desired.
- d. Analog Outputs: The GLD-30 comes standard with four (4) separate 4-20mA analog outputs. In this section, each output can be selected to represent any one of the four channels.
 - i. The analog output number is displayed at the top of the screen. For each analog output, use the up and down arrow to scroll through the four channels until the desired channel is indicated. Then press ENTER. This will record your selection and present the next analog output.
- e. Diagnostics: This section allows the user to see the actual signal condition of each channel, the status of Relay 5, the status of the horn, the status of the digital input (for remote acknowledge) and the power supply status.
 - i. Test Horn & Relays: In addition, the diagnostics section allows the user to test-operate the horn and / or relays. Using the up and down arrow, toggle to "Go to Test Screens" then press ENTER. When on the test screens, pressing the up arrow initiates the test. Releasing the up arrow ends the test.
 1. The first test screen allows the relays to be activated using the up arrow button. Press ENTER to reach the horn test screen
 2. The second test screen allows the horn to be activated using the up arrow button.
- f. Main Menu: Selecting "Main Menu" returns the unit to the main operating screen (exits the password-protected menus).

Bump Testing the GLD-30:

Note: Archer Instruments recommends periodic "bump testing" of installed gas sensors in order to verify responsiveness. Bump testing is a simple and effective way to ensure your leak detector is prepared to respond in the event of an actual gas leak. A squeeze bottle is provided with each GLD-30 for this purpose.

- 1) Chlorine Sensors: Mix a solution one-part vinegar and one-part bleach and pour a small amount into the squeeze bottle (¼ of the bottle is plenty). Holding the bottle 12" below the sensor, gently squeeze the fumes from the bottle (once) to test for responsiveness. **Do not allow the liquid solution to contact the sensor element, as this will damage the sensor.**
- 2) Sulfur Dioxide Sensors: A simple and easy way to bump test a sulfur dioxide sensor is to strike a normal sulfur match at least 12" below the sensor.
- 3) Ammonia Sensors: Ammonia sensors can be bump tested using normal household ammonia, in the same manner described above for chlorine (using the squeeze bottle provided).
- 4) Other Sensors: Consult factory.

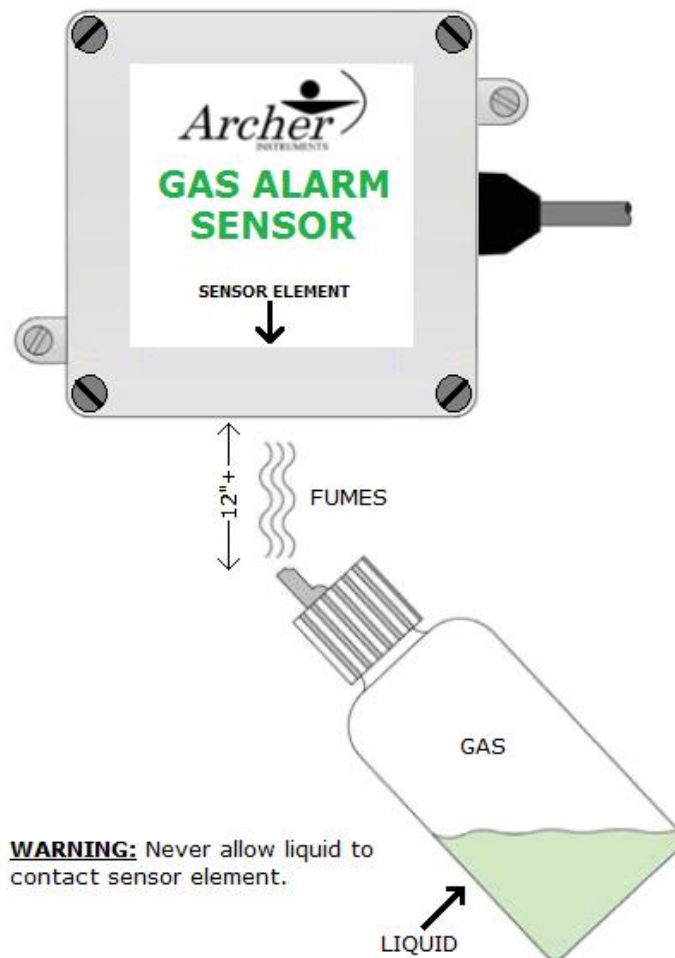

BUMP TEST ILLUSTRATION